

Structural Calculations for:

Day Residence Remodel

**37825 SE 76th Street
Mercer Island Washington**

Client: Sturman Architects

25 May 2023



Index:

| | |
|------------|---|
| KP- | Key Plans |
| UF- | Upper Floor and Low Roof Framing |
| MF- | Main Floor Framing and Foundations |

giraf design

9220 Roosevelt Way NE Seattle WA 98115-2842
(206) 621-0060 Office (206) 898-4229 Cell
girafdesign@gmail.com <http://girafdesign.net>

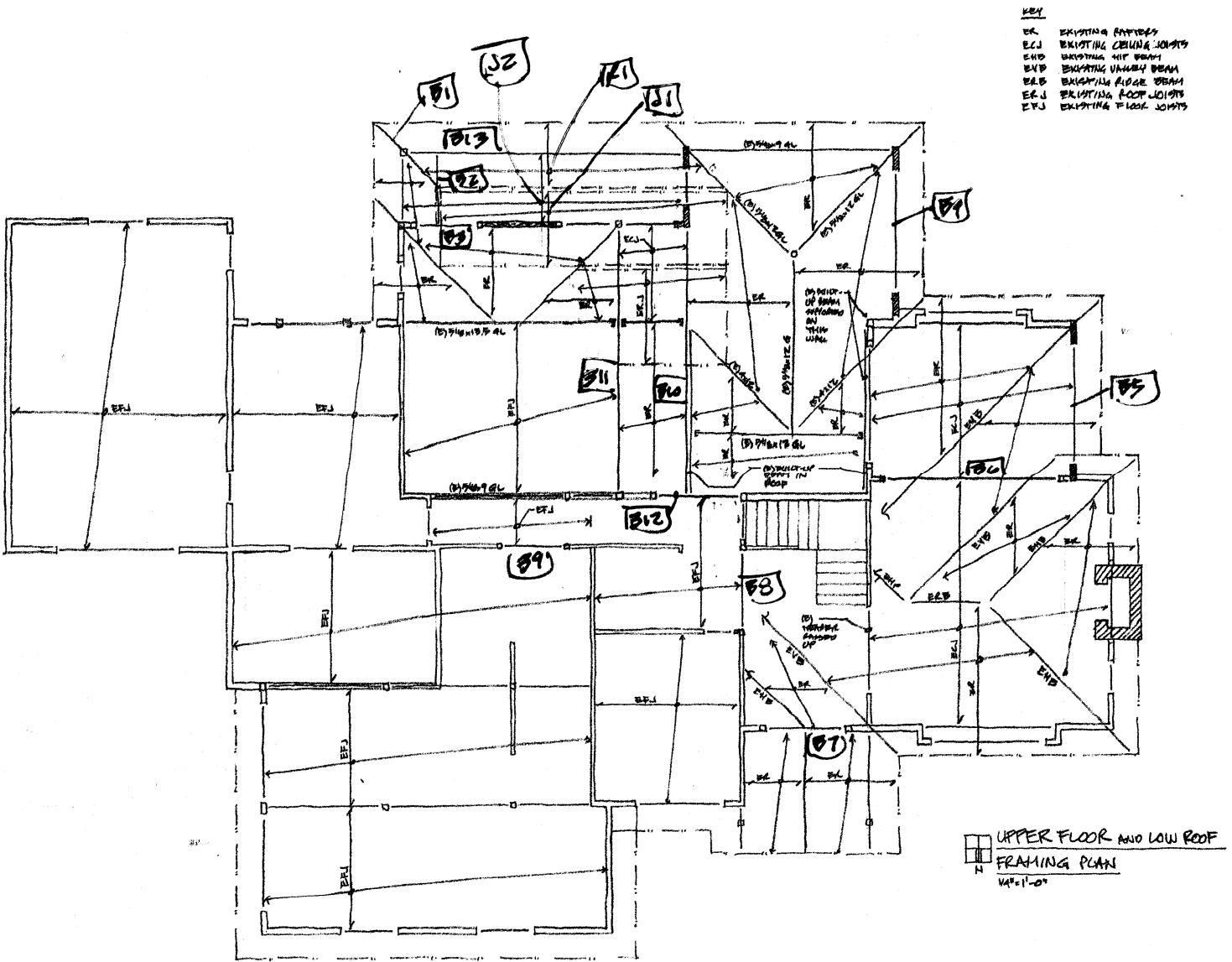

giraf design
 9220 roosevelt way ne
 seattle wa 98115-2842
 (206) 621-0060 office
 (206) 898-4229 cell
girafdesign@gmail.com
<http://girafdesign.net>

project: DAY REMODEL

date: 5-21-23

proj #: 2022-056

client: STORMAN ARCHITECTS

sheet: KP-1

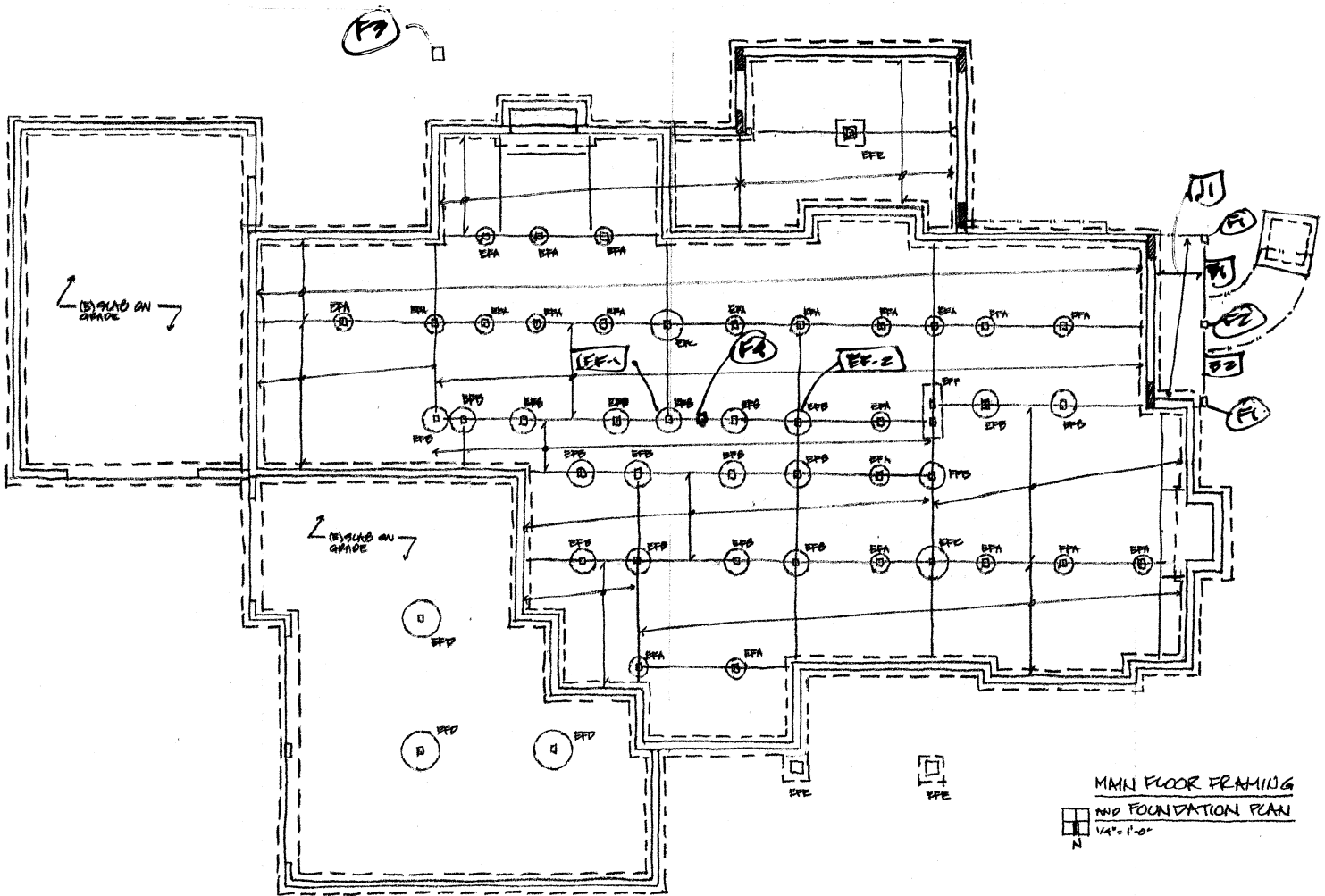

giraf design
 9220 roosevelt way ne
 seattle wa 98115-2842
 (206) 621-0060 office
 (206) 898-4229 cell
girafdesign@gmail.com
<http://girafdesign.net>

project: DAY REMODEL
 client: STURMAN ARCHITECTS

date: 5-24-23
 proj #: 2022.056
 sheet: KP-2

UPPER FLOOR & LOW ROOF FRAMING

(SEE KP-1)

RAPTERS 24" o.c.

[R1]

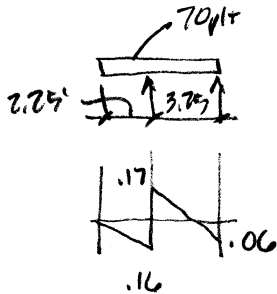

M = .18 FTL
2x8 (4F#2)

ROOF JOISTS 24" o.c.

[J1] L = 6' H = 132FTL
W = 70plf V = .21k

2x8 (4F#2)

CEILING JOISTS 24" o.c.

[J2]

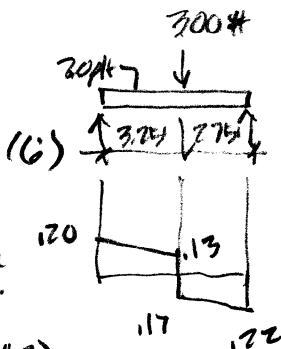

M = .54 FTL
V = .22k

2x8 (4F#2)

BEAMS

[B1]

W = .32k

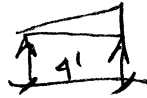

M = .116 FTL
V = .21k

(2) 2x10

[B2]

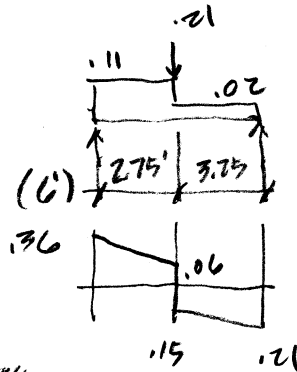

M = .158 FTL
V = .36k

(2) 2x8

[B3]

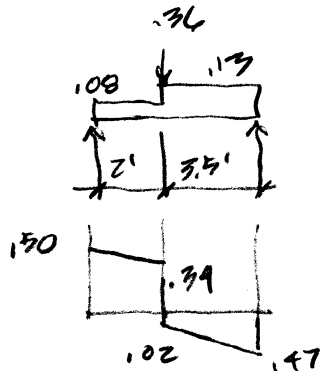

M = .181
V = .150k

(2) 2x8

[B4] L = 10.25' H = 3.41FTL
W = .26k V = 1.33k

3 1/2 x 9 GL DTU < 4/600

[B5] L = 10'
W = .26

3 1/2 x 9 GL

[B6] L = 14.5' M = 19.20FTL
W = .73k V = 5.31k

TP4 3 1/2 x 11 7/8 PSL

DTU < 4/257

USE 3 1/2 x 14 PSL

DTU < 4/472

[B7] L = 7' M = 2.163FTL
P = 1.5k V = .75k

4x8 (DF/L #15)

DTU < 4/800

[B8]

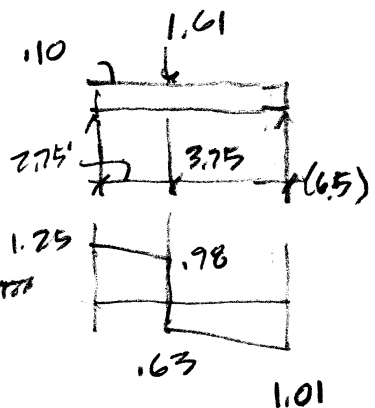

M = 3.06 FTL
V =

(2) 2x10

B9 $l = 5.5'$ $M = 2.91 \text{ Ft-k}$
 $W = .77 \text{ k}$ $V = 2.11 \text{ k}$
4x8

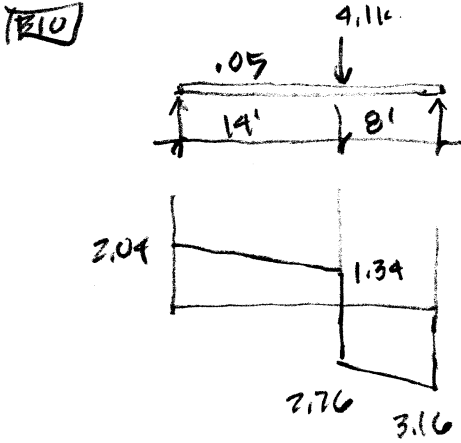

$M = 23.7 \text{ Ft-k}$
 $V = 3.16 \text{ k}$

3 1/2 x 18 PSL $\Delta_{TL} = 4/902$

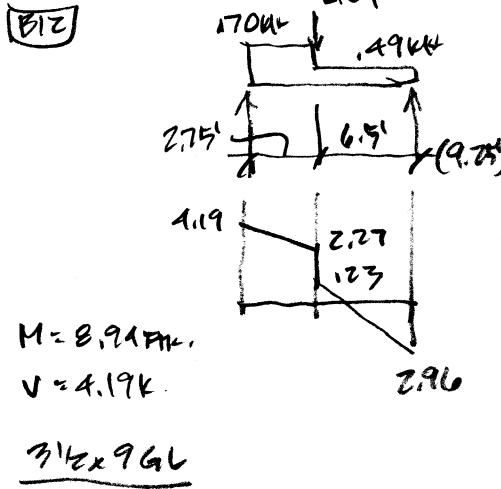

$M = 8.91 \text{ Ft-k}$
 $V = 4.19 \text{ k}$

3 1/2 x 9 GL

B13 $l = 22.75'$ $M = 17.47 \text{ Ft-k}$
 $W = .27 \text{ k}$ $V = 3.07 \text{ k}$
 TRY 7x9 1/2 PSL
 $\Delta_{TL} = 4/185$
7x11 7/8 PSL $\Delta_{TL} = 4/960$
 STEEL THIN = 74.1104
W8x28 $\Delta_{TL} = 4/276$

B11 $W = .49 \text{ k}$
 $W_1 = .1311 \text{ k}$ 1.73 k

$P = 3.62 \text{ k}$ ∇
 2.52 k L
 5.95 k S
 $W_2 = .05 \text{ k}$ ∇

LOAD CASE 4
 CRITICAL

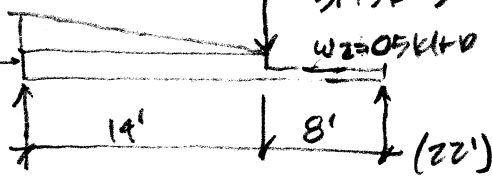

$W_1 = .13 \text{ k}$
 $W_2 = .05 \text{ k}$
 $W = 1.91 \text{ k}$
 $P = 9.97 \text{ k}$

$M = 58.8 \text{ Ft-k}$
 $V = 7.55 \text{ k}$

TRY W8x28 $\Delta_{TL} = 4/990$

W8x40 $\Delta_{TL} = 4/582$

giraf design
 9220 roosevelt way ne
 seattle wa 98115-2842
 (206) 621-0060 office
 (206) 898-4229 cell
girafdesign@gmail.com
<http://girafdesign.net>

project: DRY RENOVEL

client: STURMAN ARCHITECTS

date: 5-24-23

proj #: 2022-056

sheet: UF-2

**MAIN FLOOR
FRAMING & FOUNDATIONS**

(SEE KP-2)

JOISTS 16" o.c.

J1 $L = 4'$ $M = .197k$
 $w = 93/ft$ $V =$

BEAMS

B1 & B2

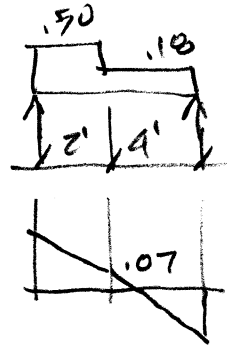

1.07

$M = 1.17k$
 $V = 1.07k$

AXIS (P.T.)

FOOTINGS

F1 $P = .65k$ 18" x 18" x 10"

F2 $P = 2.14k$ 24" x 24" x 10"

F3 $P = 3.6k$ 24" x 24" x 10"
 $qs < 1500 psf$

F4 SUPPORTING LOAD
FROM ABOVE +
(E) BEAM

$P = 5.67k$

$ABMIN = 3.78\psi$

24" x 24" x 10"

EXISTING FOOTINGS
w/ INCREASED LOADS

EF-1 $P = 9.37k$

(E) 24" ϕ $qs = 2980 psf$ NG

ADD TO (E) $ABMIN = 6.29$

2'-0" x 4'-0" MIN

EF-2 $P = 7.82k$

(E) 24" ϕ $qs = 2490 psf$ NG

ADD TO (E) 2' x 4' MIN

giraf design

9220 roosevelt way ne
seattle wa 98115-2842
(206) 621-0060 office
(206) 898-4229 cell
girafdesign@gmail.com
<http://girafdesign.net>

project: DAY REMODEL

date: 5-22-23

proj #: 2022-056

client: STURMAN ARCHITECTS

sheet: MF-1